



Critical Service

Safety Relief Valves

Series 546

Series 447

CATALOG

LESER

The-Safety-Valve.com

How to find the right Product Group

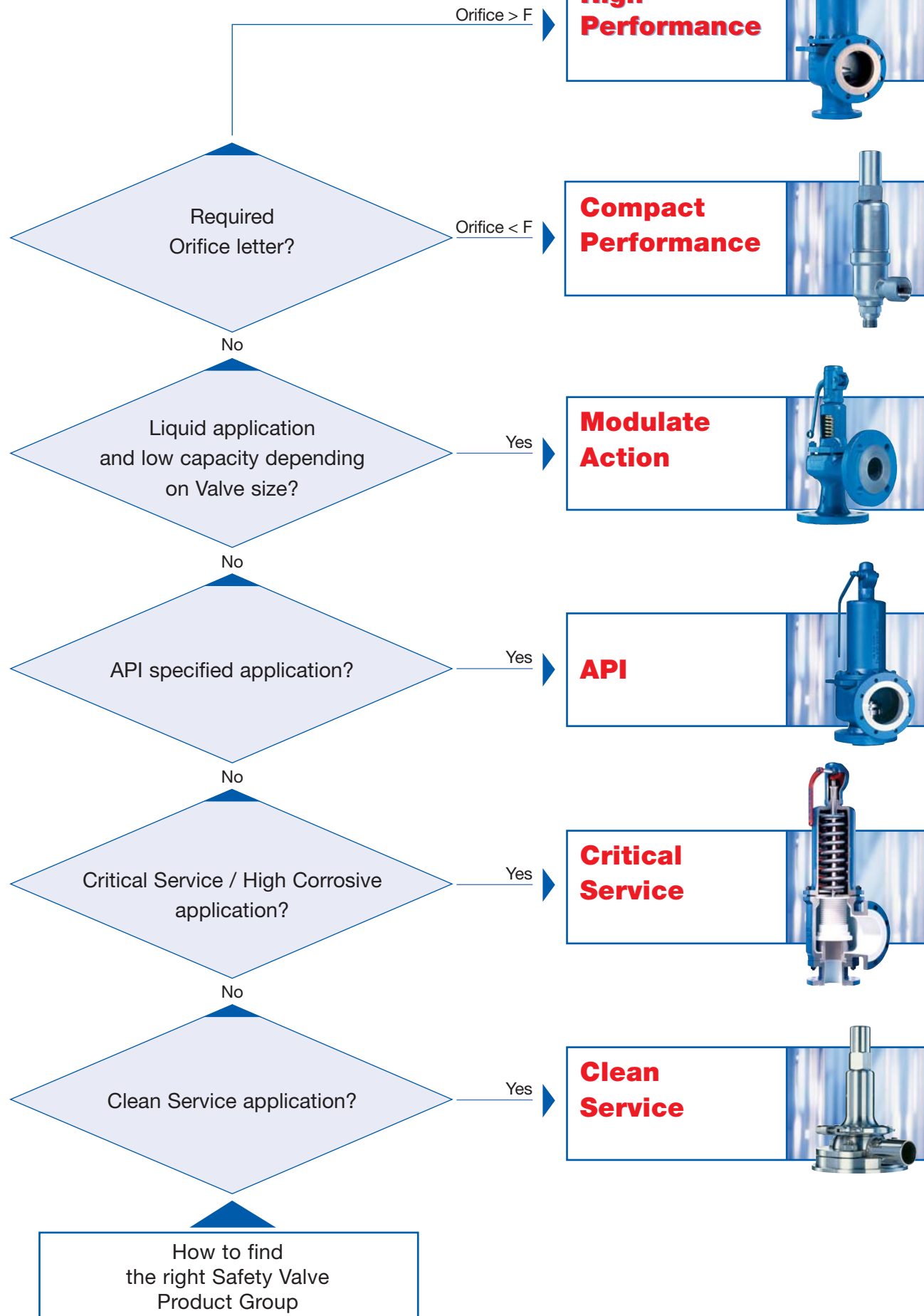

**Type
546**

Normal-Feder-Sicherheitsventil mit PTFE-Buchse

Safety Relief Valve spring loaded, semi lined

für Dämpfe, Gase und Flüssigkeiten
for steam, gases and liquids

Zusatzrüstungen

Edelstahl-Faltenbalg
PTFE-Faltenbalg
Teller-Dichtplatte aus Sonderwerkstoffen
**Detailinformationen und weitere
Zusatzrüstungen siehe Teil 13**

Accessories

Stainless steel bellows
PTFE bellows
Disc sealing plate in special materials
**For detailed information and additional
accessories refer to section 13**

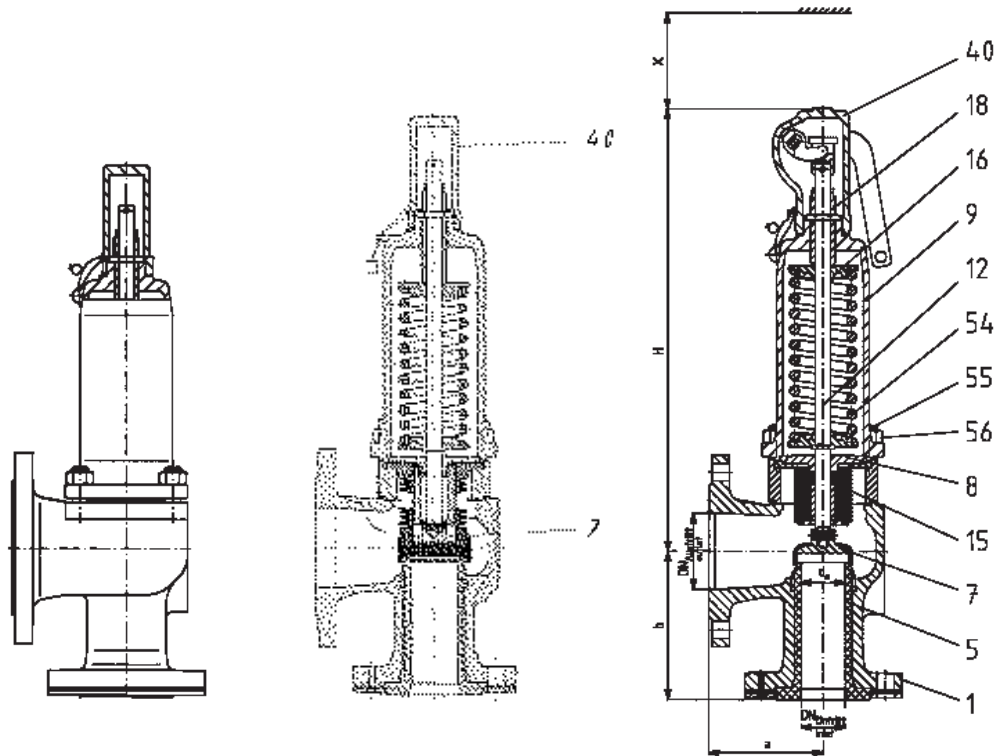

Type 546
mit gasdichter Kappe H 2
with gastight cap H 2

Type 546 F
mit gasdichter Kappe H 2,
mit PTFE-Faltenbalg,
Austritt durch Spezialbeschichtung
korrosionsgeschützt
with gastight cap H 2, with PTFE bellows,
outlet corrosion protected by special coating

Type 546
geschlossene Federhaube mit Anlüftung H 4
gasdicht, Teller anlüftbar
mit Edelstahl Faltenbalg
closed bonnet
lifting device H 4, gastight
disc liftable, with stainless steel bellows

Zulassungen/Approvals

	Dämpfe/Gase D/G <i>Steam/Gases S/G</i>	Flüssigkeiten F <i>Liquids L</i>
TÜV (AD-A2, TRD 421) Listennr./Approval number Ausflussziffer/Coefficient of discharge α_d Öffnungscharakteristik/Opening characteristic	496 DN 25: 0,73 / DN 40-65: 0,68 / DN 80-100:0,64 Normal/Standard	496 DN 25: 0,46 / DN 40-65: 0,43 / DN 80-100:0,4 Normal/Standard
Weitere/Others siehe Seite/refer to page 2/40-41	ISPESL, SVTI, SN 132150, 132151	

Gehäusewerkstoff <i>Body material</i>		DN		Flanschanschlüsse ¹⁾ <i>Flange connections ¹⁾</i>		Temperatureinsatzbereich ²⁾ <i>Temperature range ²⁾</i>		Type
DIN EN		von	bis	nach/acc. to DIN PN		von	bis	
Werkstoffbezeichnung <i>Material Designation</i>	Werkstoff-Nr. <i>Material No.</i>	from	to	Eintritt <i>Inlet</i>	Austritt <i>Outlet</i>	from	to	
GGG-40.3	0.7043	40	100	16	16	-60/-76	+200/+392	5465
GP 240 GH	1.0619	25	80	40	16	-60/-76	+200/+392	5462

¹⁾ Anschlussmaße nach ANSI B16.5 150 lbs. möglich.

²⁾ Zwischen -10 °C und der niedrigsten angegebenen Anwendungstemperatur ist gemäß AD-Merkblatt W10 zu verfahren.

¹⁾ Dimensions acc. to ANSI B16.5 150 lbs. possible.

²⁾ Between -10 °C and lowest temperature indicated "AD-Merkblatt" W10 shall be taken into account.

Änderungen behalten wir uns vor.

Modifications reserved.

Artikelnummern / Article Numbers

Gehäusewerkstoff <i>Body material</i>		Nennweite / Nominal Diameter									
DIN EN											
Werkstoffbezeichnung <i>Material Designation</i>	Werkstoff-Nr. <i>Material No.</i>	25	40	50	65	80	100				
GGG-40.3	0.7043	5465	-	.372*	-	.374*	-	.376*			
GP 240 GH	1.0619	5462	.380*	-	.381*	-	.382*	-			

* Bitte hier gewünschte Ziffer für Kappe oder Anlüftung anfügen:

* Please add number for the required cap or lifting device:

2 = Kappe **H 2**
4 = Anlüftung **H 4** (gasdicht)

2 = Cap **H 2**
4 = Lifting device **H 4** (gastight)

Bei Bestellung bitte Artikelnummer, Ansprechdruck und ggf. Zusatzausrüstung (siehe Teil 13) bzw. Ausführung „F“ (nur mit Gehäuse aus GP 240 GH/1.0619) angeben.

In event of order please state article number set pressure and if necessary, accessories (refer to section 13), resp. design "F" (only with body in cast steel).

Abmessungen, Druckbereiche, Gewichte / Dimensions, Pressure Ranges, Weights

Nennweite, Ventilgröße		Nominal Diameter, Valve size		DN	-	25	40	50	65	80	100				
Nennweite, Austritt		Nominal Diameter, Outlet		DN	-	40	65	80	100	125	150				
Druckstufe	GGG	Pressure rating	NCl	PN	-	16									
Eintritt	GS	Inlet	CS	PN	-	40									
Druckstufe Austritt		Pressure rating Outlet		PN	-	16									
Max. Ansprechdruck		Max. Set pressure		p	bar/bar g	10 (16)									
Engster Strömungsquerschnitt		Flow area		A _o	mm ²	416	1075	1662	2827	4072	5945				
Engster Strömungsdurchmesser		Flow diameter		d _o	mm	23	37	46	60	72	87				
Schenkellänge		Centre to face dim.			a	mm	100	115	120	140	160	180			
					b	mm	105	140	150	170	195	220			
Bauhöhe	H 2	Height	H 2	H	mm	231	355	402	409	502	576				
	H 4		H 4	H	mm	227	371	418	425	543	616				
	mit Faltenbalg zus.		with bellows add.	H	mm	68	69	52	80	97	89				
Deckenfreiheit		Height clearance		x	mm	200	250	300	300	350	400				
Gewicht		Weight		-	kg	9	19	22	27	39	55				

Einsatzbereich in Abhängigkeit von p und t / Application range with dependence on p and t

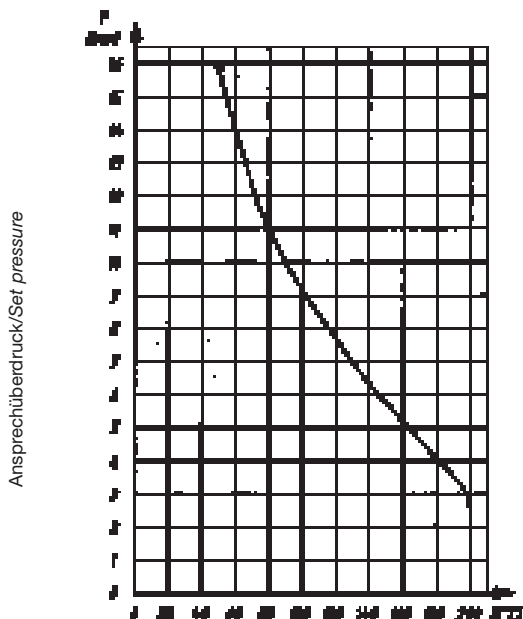

Oberhalb 10 bar Ansprechüberdruck
Sitzbuchse aus Hastelloy o. ä.
Above 10 bar g set pressure nozzle in
Hastelloy or other.

Mediumtemperatur/Fluid temperature

Werkstoffe / Materials

Pos. Item	Bauteile	Parts	5465 GGG NCI	5465 Faba GGG NCI	5462 GS CS	5462 F GS CS
1	Gehäuse	Body	GGG-40.3	0.7043	GP 240 GH	1.0619
5	Sitzdüse	Nozzle	PTFE		PTFE	PTFE-Kohle/PTFE-Carbon
7	Teller/Dichtplatte	Disc/Sealing Plate	X 2 Cr Ni Mo 17-12-2/Tempaxglas		1.4404/Tempaxglas	X 2 Cr Ni Mo 17-12-2 1.4404 PTFE-Kohle/PTFE-Carbon
8	Führungsscheibe	Guide	X 2 Cr Ni Mo 17-12-2 GX5 Cr Ni Mo 19-11-2			1.4404 1.4408
9	Federhaube	Bonnet	GGG-40		0.7040	GGG-40.3 0.7043
12	Spindel	Spindle	X 20 Cr 13			1.4021
15	Faltenbalg	Bellows		X 6 Cr Ni Mo Ti 17-12-2 1.4571		PTFE PTFE
16	Federteller	Spring plate	11 S Mn Pb 30			1.0718
18	Druckschraube mit Buchse	Adjusting screw with bush	X 14 Cr Mo S 17 PTFE			1.4104 PTFE
54	Feder	Spring	Federstahldraht C/Spring steel wire C 54 Si Cr 6/51 CrV 4/X 10 Cr Ni 18-8			1.1200/1.7102/1.8159/1.4310
40	Kappe H 2 Anlüftung H 4	Cap H 2 Lifting device H 4	11 S Mn Pb 30/GGG 40.3 GGG-40			1.0718/0.7043 0.7040
55/ 56	Stiftschraube Mutter	Bolt nut	Ck 35/C 35			1.1181/1.0501

Zuerkannte Ausflußziffer α_d / Coefficient of Discharge α_d

Diagramm 1

$$\alpha_d = f(h/d_o)$$

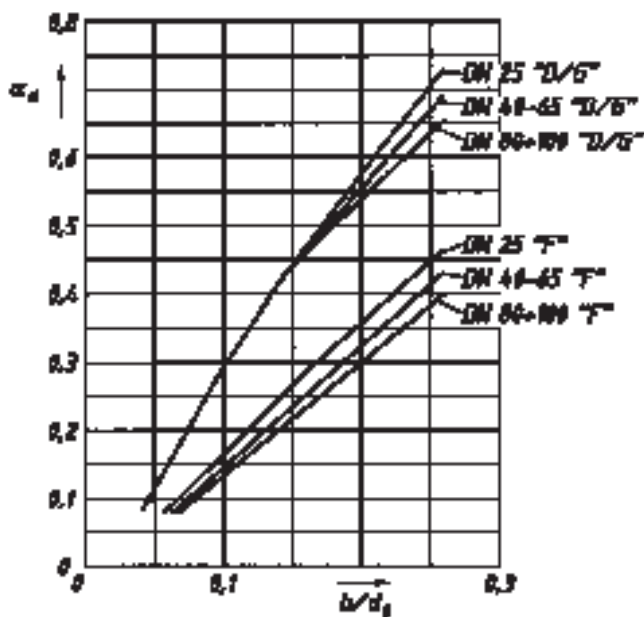

h = Hub (mm)
 d_o = engster Strömungsdurchmesser (mm)
 p_{a0} = Gegendruck, bar (abs.)
 p_o = Ansprechdruck, bar (abs.)

Diagramm 2

$$\alpha_d = f(p_{a0}/p_o)$$

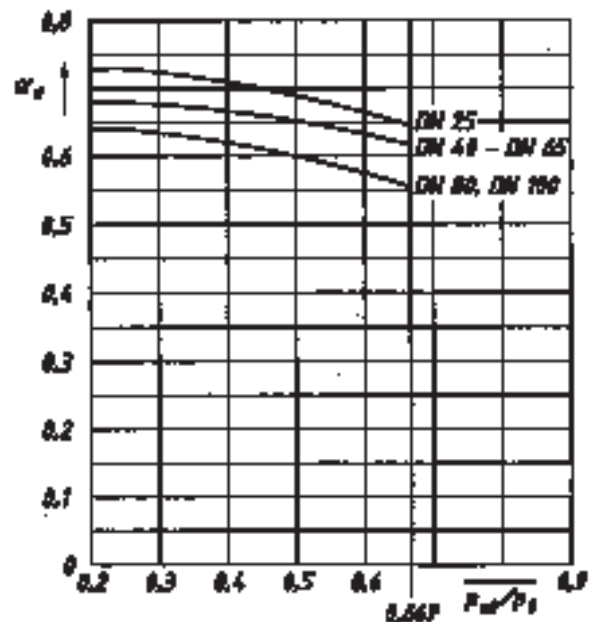

h = Lift (mm)
 d_o = Flow diameter (mm)
 p_{a0} = Back pressure, bar (abs.)
 p_o = Set pressure, bar (abs.)

**Type
447**

Normal-Feder-Sicherheitsventil mit PTFE-Vollauskleidung Safety Relief Valve spring loaded, fully PTFE lined

für Dämpfe, Gase und Flüssigkeiten
for steam, gases and liquids

Zusatzausrüstungen

Teller-Dichtplatte aus Hastelloy,
Monel oder Inconel

Sitzbuchse aus Hastelloy

Detailinformationen und weitere

Zusatzausrüstungen siehe Teil 13

Accessories

Disc sealing plate in Hastelloy,
Monel or Inconel

Nozzle in Hastelloy

**For detailed information and additional
accessories refer to section 13**

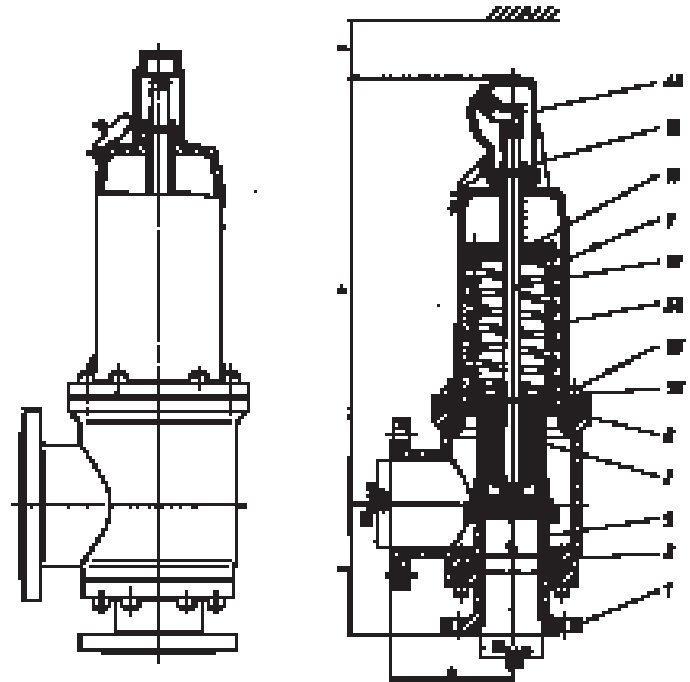

Type 447
mit gasdichter Kappe H 2
with gastight cap H 2

Type 447
geschlossene Federhaube mit
Anlüftung H 4
Teller anlüftbar
closed bonnet lifting device H 4
disc liftable

Zulassungen/Approvals

	Dämpfe/Gase D/G Steam/Gases S/G				Flüssigkeiten F Liquids L			
	DN 25	DN 50	DN 80	DN 100	DN 25	DN 50	DN 80	DN 100
TÜV (AD-A2, TRD 421) Listennr./Approval number Ausflussziffer/Coefficient of discharge α_d Öffnungscharakteristik/Opening characteristic	979				979			
	0,7	0,72	0,7	0,65	0,48	0,47	0,51	0,42
	Normal/Standard				Normal/Standard			
ASME/NB Nr./No. Ausflussziffer/Coefficient of discharge K	37123 0,617				37134 0,431			
Weitere/Others siehe Seite/refer to page 2/40-41	CBPVI DGR/PED	KISCO GOST	DNV TMBEF					

Gehäusewerkstoff Body material			DN		Flanschanschlüsse nach Flange connections acc. to				Temperatureinsatzbereich °C ¹⁾ Temperature range °F ¹⁾				Type		
DIN EN		ASME	von	bis	DIN PN		ANSI B 16,5		DIN EN		ASME				
Werkstoffbezeichnung Material Designation	Werkstoff-Nr. Material No.		from	to	Inlet	Outlet	Inlet	Outlet	from	to	from	to			
S355J2G3	1.0570	Carbon steel	25	100	1"	4"	16	16	#150	#150	-85/-121	+200/+392	-85/-121	+200/+392	4472

¹⁾ Zwischen -10 °C und der niedrigsten, angegebenen Anwendungstemperatur ist gemäß AD-Merkblatt W10 zu verfahren.

¹⁾ Between -10 °C and lowest temperature indicated "AD-Merkblatt" W10 shall be taken into account.

Änderungen behalten wir uns vor.

Modifications reserved.

Artikelnummern / Article Numbers

Gehäusewerkstoff <i>Body material</i>			Nennweite /Nominal Diameter												
DIN EN	Werkstoff-Nr. <i>Material No.</i>	ASME	DN NPS	25 1"	50 2"	80 3"	100 4"								
S355J2G3	1.0570	<i>Carbon steel</i>	4472	.387*	.388*	.389*	.390*								

* Bitte hier gewünschte Ziffer für Kappe oder Anlüftung anfügen:

- 2 = Kappe **H 2**
- 4 = Anlüftung **H 4** (gasdicht)

Bei Bestellung bitte Artikelnummer entsprechend Bestellbeispiel im Teil 1, Ansprechdruck und ggf. Zusatzausrüstung (siehe Teil 13) angeben.

* Please add number for the required cap or lifting device:

- 2 = Cap **H 2**
- 4 = Lifting device **H 4** (gastight)

In event of order please state article number corresponding to the example for ordering in section 1, set pressure and if necessary, accessories (refer to section 13).

Abmessungen, Druckbereiche, Gewichte / Dimensions, Pressure Ranges, Weights

Nennweite, Ventilgröße		<i>Nominal Diameter, Valve size</i>		DN	-	25	50	80	100								
Nennweite, Austritt		<i>Nominal Diameter, Outlet</i>		DN	-	50	80	100	150								
Druckstufe Eintritt		<i>Pressure rating Inlet</i>		PN	-	16											
Druckstufe Austritt		<i>Pressure rating Outlet</i>		PN	-	16											
Nennweite, Ventilgröße		<i>Nominal Diameter, Valve size</i>		DN	-	1"	2"	3"	4"								
Nennweite, Austritt		<i>Nominal Diameter, Outlet</i>		DN	-	2"	3"	4"	6"								
Druckstufe Eintritt		<i>Pressure rating Inlet</i>		PN	-	#150											
Druckstufe Austritt		<i>Pressure rating Outlet</i>		PN	-	#150											
Max. Ansprechdruck		<i>Max. Set pressure</i>		p	bar/bar g	16											
Engster Strömungsquerschnitt		<i>Flow area</i>		A ₀	mm ²	415	1662	2827	6648								
Engster Strömungsdurchmesser		<i>Flow diameter</i>		d ₀	mm	23	46	60	92								
Schenkellänge		<i>Centre to face dim.</i>			a	mm	100	120	155	200							
					b	mm	105	152	155	220							
Bauhöhe	H 2	<i>Height</i>	H 2	H	mm	348	436	593	675								
	H 4		H 4	H	mm	364	452	631	723								
Deckenfreiheit		<i>Height clearance</i>		x	mm	200	300	400	450								
Gewicht		<i>Weight</i>		-	kg	15	29	50	105								

Einsatzbereich in Abhängigkeit von p und t / **Application range** with dependance on p and t

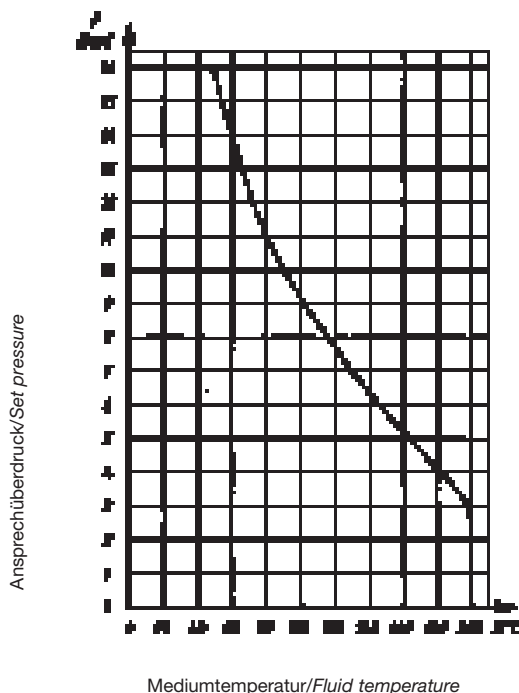

Oberhalb 10 bar
 Ansprechüberdruck
 Sitzbuchse aus Hastelloy o. ä.
 Above 10 bar g set pressure
 nozzle in Hastelloy or similar.

Werkstoffe / Materials

Pos. Item	Bauteile	Parts	4472	
			GS	CS
1	Eintrittsstutzen	Inlet socket	S 355J2G3 PTFE (PTV 070)	1.0570 PTFE (PTV 070)
2	Austrittsgehäuse	Outlet chamber	GP 240 GH/PTFE (PTV 070)	1.0619/PTFE (PTV 070)
5	Sitzbuchse	Nozzle	PTFE/25% Glas / PTFE/25% glas ¹⁾	
7	Teller/Faltenbalg	Disc/Bellows	PTFE/Borofloat	
8	Führungsscheibe	Guide	X 2 Cr Ni Mo 17-12-2	1.4404
9	Federhaube	Bonnet	GGG-40 (GGG-40.3/GP 240 GH)	0.7040 (0.7043/1.0619)
12	Spindel	Spindle	X 20 Cr 13	1.4021
16	Federteller	Spring plate	11 S Mn Pb 30	1.0718
18	Druckschraube mit Buchse	Adjusting screw with bush	X 14 Cr Mo S 17 PTFE	1.4104 PTFE
54	Feder	Spring	Federstahldraht / Spring steel wire	
40	Kappe H 2 Anlüftung H 4	Cap H 2 Lifting device H 4	11 S Mn Pb 30/GGG-40.3 GGG-40	1.0718/0.7043 0.7040
55/ 56	Stiftschraube Mutter	Bolt nut	Ck 35/C 35	1.1181/1.0501

1) Bei Ansprechdrücken höher als 10 bar aus hochkorrosionsbeständigem Werkstoff.
At set pressures higher than 10 bar g made of high corrosion resistant material.

Zuerkannte Ausflußziffer α_D / Coefficient of Discharge α_D

Diagramm 1

$$\alpha_D = f(h/d_0)$$

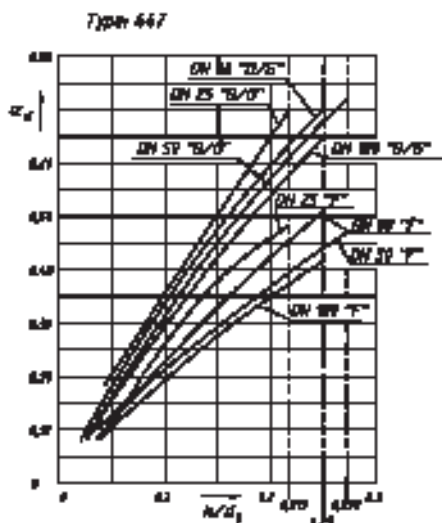

h = Hub (mm)
d₀ = engster Strömungsdurchmesser (mm)
p_{a0} = Gegendruck, bar (abs.)
p₀ = Ansprechdruck, bar (abs.)

Diagramm 2

$$\alpha_D = f(p_{a0}/p_0)$$

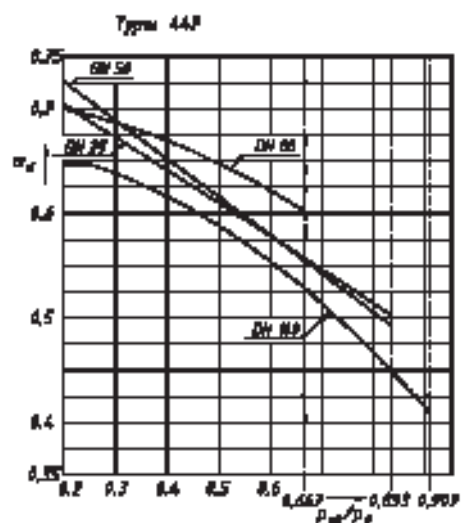

h = Lift (mm)
d₀ = Flow diameter (mm)
p_{a0} = Back pressure, bar (abs.)
p₀ = Set pressure, bar (abs.)

Type 447

Leistungstabelle				Discharge Capacities			
Berechnungen aus VALVESTAR® 6.2.50				Calculations from VALVESTAR® 6.2.50			
Berechnung entsprechend DIN 3320, AD2000-Merkblatt A2, TRD 421				Calculations of mass flow according to DIN 3320, AD2000-Merkblatt A2, TRD 421			
p	Ansprechüberdruck			Set pressure			bar g
I	Sattdampf			Saturated steam			kg/h
II	Luft bei 0°C und 1013 mbar			Air at 0°C and 1013 mbar			m ³ /h
III	Wasser bei 20°C			Water at 20°C			10°kg/h

DN	25			50			80			100								
d _O (mm)	23			46			60			92								
p	I	II	III	I	II	III	I	II	III	I	II	III						
0,1		125	4,54		477	17,8		883	32,8		1702	63,5						
0,2		158	5,56		621	21,8		1142	40,2		2280	77,8						
0,3		193	6,42		743	25,1		1389	46,4		2798	89,8						
0,4		223	7,17		861	28,1		1602	51,9		3248	100						
0,5		248	7,86		975	30,8		1780	56,8		3688	110						
1		368	10,6		1450	41,7		2588	76,9		5514	149						
2		607	15,0		2426	58,9		4190	109		9126	211						
3		839	18,4		3406	72,2		5713	133		12652	258						
4		1069	21,3		4400	83,3		7278	154		15889	298						
5		1287	23,8		5296	93,2		8761	172		19126	333						
6		1505	26,1		6193	102		10243	188		22362	365						
7		1723	28,1		7089	110		11726	204		25599	394						
8		1941	30,1		7985	118		13208	218		28836	421						
9		2159	31,9		8882	125		14691	231		32073	447						
10		2377	33,6		9778	132		16173	243		35309	471						
12		2812	36,9		11571	144		19138	266		41783	516						
14		3248	39,8		13363	156		22104	288		48256	557						
16		3684	42,6		15156	167		25069	308		54729	596						

Leistungstabelle				Discharge Capacities			
Berechnungen aus VALVESTAR® 6.2.50				Calculations from VALVESTAR® 6.2.50			
Berechnung entsprechend ASME Boiler and Pressure Vessel Code, Sec. VIII, Div. 1 mit 10 % Drucksteigerung und der zuerkannten Ausflussziffer K. Leistungen unterhalb 30 psig sind mit 3 psi Drucksteigerung berechnet.				Calculation of mass flow according to ASME Boiler and Pressure Vessel Code, Sec. VIII, Div. 1 at 10 % overpressure and with certified coefficient of discharge K. Capacities below 30 psig are calculated including 3 psi overpressure.			
p	Ansprechüberdruck			Set pressure			psig
I	Sattdampf, Abblasen gegen Atmosphärendruck (14,7 psi)			Saturated Steam, valve discharging to atmospheric pressure (14,7 psi)			lb/h
II	Luft bei 60°F, Abblasen gegen Atmosphärendruck (14,7 psi)			Air at 60°F, valve discharging to atmospheric pressure (14,7 psi)			SCFM
III	Wasser bei 70°F			Water at 70°F			U.S. gallons per minute

DN	25			50			80			100								
	1 x 2			2 x 3			3 x 4			4 x 6								
d _O (mm)	23			46			60			92								
p	I	II	III	I	II	III	I	II	III	I	II	III						
15		237	44,7		948	179		1613	305		3792	716						
20		273	50,6		1094	202		1861	344		4375	809						
40		427	70,0		1706	280		2903	476		6824	1119						
60		587	85,7		2348	343		3994	583		9390	1371						
80		747	98,9		2989	396		5086	673		11956	1583						
100		908	111		3631	442		6177	753		14522	1770						
120		1068	121		4272	485		7269	825		17088	1939						
140		1228	131		4913	524		8360	891		19654	2094						
160		1389	140		5555	560		9452	952		22220	2239						
180		1549	148		6196	594		10543	1010		24786	2375						
200		1709	156		6838	626		11634	1065		27352	2503						
220		1870	164		7479	656		12726	1117		29917	2625						

Please send your request to our Sales Center

To: **LESER GmbH & Co. KG**

Fax: +49 (40) 251 65-500

Date: _____

From: _____

Catalog order:

High Performance [Catalog 1](#)

Flanged Safety Relief Valves

Series 441
Series XXL
Series 444

pdf

Printed version

No. of copies: _____

High Performance [Catalog 2](#)

Flanged Safety Relief Valves

Series 441 Full nozzle
Series 458

pdf

Printed version

No. of copies: _____

Compact Performance

Threaded Safety Relief Valves

Series 437
Series 459

pdf

Printed version

No. of copies: _____

API

Flanged Safety Relief Valves

Series 526

pdf

Printed version

No. of copies: _____

Clean Service

Safety Relief Valves

Series 48X

pdf

Printed version

No. of copies: _____

Critical Service

Safety Relief Valves

Series 447
Series 546

pdf

Printed version

No. of copies: _____

Modulate Action

Flanged Safety Relief Valves

Series 429
Series 433

pdf

Printed version

No. of copies: _____

S & R

Safety Relief Valves
for special or regional
applications

Series L & W
Series TRDF
Series TRDG
Series SBD
Type 612

pdf

Printed version

No. of copies: _____

CD order:

VALVESTAR®

- Ultimate sizing program
- Consideration of all relevant codes and standards
- Comprehensive documentation (sectional drawings, parts lists)
- Different language versions
- Help function

No. of copies: _____

Addressee

Please send the requested copies to:

Name: _____

Company: _____

Address: _____

E-Mail: _____

Critical Service Catalog
Edition April 2006

LWN 484.01-E / 04.2006 / 1500

LESER

The-Safety-Valve.com

LESER GmbH & Co. KG

20537 Hamburg, Wendenstr. 133-135
20506 Hamburg, P.O.Box 26 16 51

Fon +49 (40) 251 65-100
Fax +49 (40) 251 65-500

E-Mail: sales@leser.com
www.leser.com